

francis
pegler



CONCEALED BATHROOM SYSTEMS
1ST JUNE 2011

H ROOM SYSTEMS

SWISH

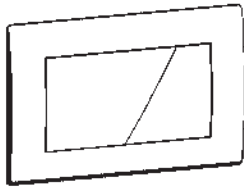

CODE: **4P9054** (MATT CHROME)
 PRICE EXC VAT: **£44.17**
 PRICE INC VAT: **£53.00**

CODE: **4P9053** (POLISHED CHROME)
 PRICE EXC VAT: **£41.67**
 PRICE INC VAT: **£50.00**

OPAL

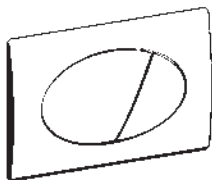

CODE: **4P9051** (POLISHED CHROME)
 PRICE EXC VAT: **£37.50**
 PRICE INC VAT: **£45.00**

CODE: **4P9052** (WHITE)
 PRICE EXC VAT: **£28.33**
 PRICE INC VAT: **£34.00**

PNEUMATIC BUTTON



CODE: **4P9059** (POLISHED CHROME)
 PRICE EXC VAT: **£70.00**
 PRICE INC VAT: **£84.00**

ANTIVANDAL FLUSH PLATE

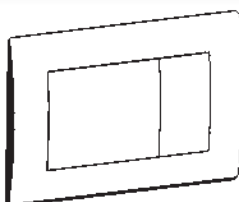

CODE: **4P9069** (STAINLESS STEEL)
 PRICE EXC VAT: **£129.17**
 PRICE INC VAT: **£155.00**

BASIN INSTALLATION SYSTEMS

WASH-BASIN FRAME

CODE: **4P9001**

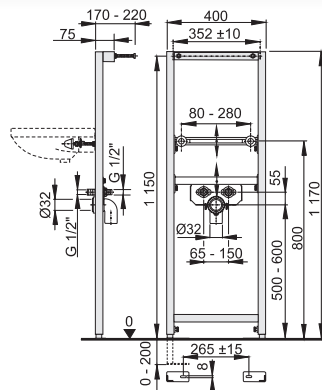

PRICE EXC VAT: **£116.67**
 PRICE INC VAT: **£140.00**

CODE: **4P9002**

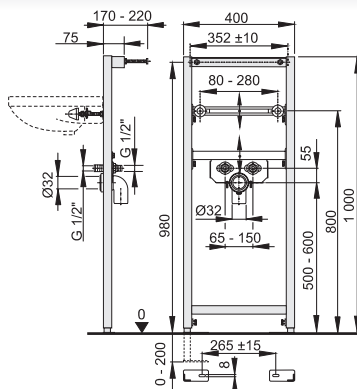

PRICE EXC VAT: **£129.17**
 PRICE INC VAT: **£155.00**

BIDET INSTALLATION SYSTEMS

BIDET FRAME

CODE: **4P9003**

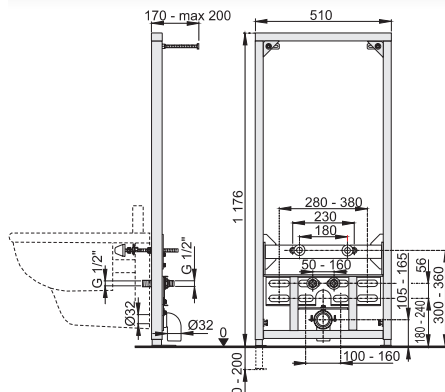

PRICE EXC VAT: **£166.67**
 PRICE INC VAT: **£200.00**

CODE: **4P9004**

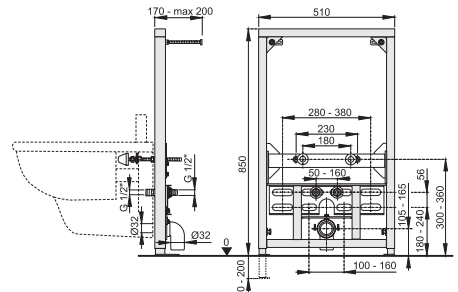

PRICE EXC VAT: **£183.33**
 PRICE INC VAT: **£220.00**

URINAL INSTALLATION SYSTEMS & ACCESSORIES

URINAL FRAME

CODE: **4P9005**

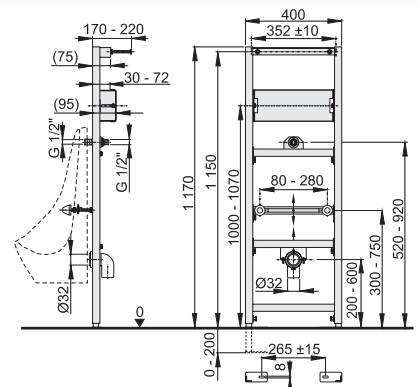

PRICE EXC VAT: **£166.67**
 PRICE INC VAT: **£200.00**

OPTIFLUSH

CODE: **599001** (9V BATTERY)

CODE: **599002** (230V MAINS)

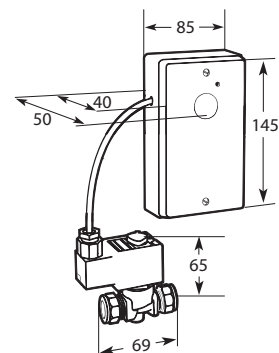

PRICE REFER TO PRESTEX LIST

Terms and conditions

1. General

In these conditions, reference to the Company shall mean Pegler Yorkshire. All quotations are made and all orders are accepted subject to these conditions. All other terms, conditions or warranties whatsoever are excluded from the contract or any variation thereof unless expressly accepted by the Company in writing. In the event of a conflict between these conditions and the specific terms and conditions of quotation then the latter shall prevail.

2. Electronic Trading

- If the Company and Buyer agree that electronic trading between them shall be a basis for order processing and invoicing then the Standard Interchange Agreement (1st Edition March 1989) of the EDI Association shall be incorporated into the contract by reference subject to these conditions.
- Electronic orders shall be valid if all the information agreed between the Buyer and the Company as being required is properly set out in the agreed format and the order is transmitted by the Buyer to the Company by reference to the correct identification code and is received by the Company when collecting its electronic mail from the relevant system.
- Each valid electronic order will be deemed accepted by the Company unless the Company communicates rejection of the order to the Buyer by electronic or other means (including telephone) within 24 hours of receipt. Acceptance of an order shall constitute a contract for sale and purchase to which these conditions and the Standard Interchange Agreement shall prevail.
- If the Company and the Buyer agree that invoicing may be done by electronic mail, then payment will be due 30 days after the date of electronic invoice unless agreed otherwise.

3. Delivery

Any date for delivery named by the Company is an estimate only and in no circumstances shall the failure of the Company to deliver on or before the named date either entitle the Buyer to rescind or terminate the contract or make the Company liable in any way for the consequences of any delay.

4. Export

Unless specifically stated otherwise in these conditions all trade terms not specifically covered by these conditions shall be interpreted in accordance with INCOTERMS current on the date of that order.

5. Warranty and Defective Goods

- Save as otherwise provided by the other conditions of these Conditions, sections 12 to 15 of the Sale of Goods Act 1979 are to be implied into this contract.
- The goods delivered under the Contract shall, where the Contract includes a specification, comply with the specification or, if there is no specification, shall be of normal industrial quality.
- The Buyer does not rely on any statement or representations other than those which have been made in writing by the Company.
- The Buyer must give the Company immediate written notice of any defect in the goods. Such goods shall be returned to the Company and if proved to have been defective at delivery as a result of faulty materials or workmanship, the Company shall at its option replace or repair such goods. Defects in quality or dimension in any delivery shall not be ground for cancellation of the remainder of the order.
- Save for any liability for death or personal injury caused by the Company's negligence, the Company's liability in connection with defective goods shall be limited to the repair or supply of a replacement for the defective goods, and the Company shall not be liable for any other loss or damage including, but not limited to loss of profit, labour costs, damage to property, wasted expenditure or cost of mitigation.

6. Data and Technical Information

The information contained in the advertising sales and technical literature issued by the Company may be relied upon to be accurate in the exact circumstances in which it is expressed. Any illustrations, performance details, examples of illustrations and methods of assembly and all other technical data in such literature are based on experience and upon trials under test conditions and are provided for general guidance only.

7. Claims For Damage, Shortage or Loss

No claim for damage in transit or shortage of delivery can be accepted unless, a separate notice in writing is given to the carrier concerned and to the Company within three days of receipt of the goods, followed by a complete claim in writing within five days of receipt of the goods. No claim for loss of goods in transit can be accepted unless a separate notice in writing is given to the carrier concerned and to the Company, and a complete claim in writing made within 21 days of the date of consignment. Where goods are accepted from the carrier concerned without being checked, the delivery book of the carrier must be signed "not examined". If a complaint is not made to the Company as herein provided, the products shall be deemed to be in all respects in accordance with the Contract, and the Buyer shall be bound to pay for the same accordingly.

8. Suspension of Deliveries

- Deliveries may be wholly or partially suspended by the company in the event of:-
 - Stoppage, delay or interruption caused to the business of the Company as a result of strikes, lockouts, trade disputes, breakdown, accident or any cause whatsoever beyond the reasonable control of the Company.
 - Any default by the Buyer in making payment of any amounts owed to the Company under this and any other contracts between them.
- In the event of any hostilities (whether war is declared or not) in which Great Britain is involved, or in the event of national emergency, or if the Company's works should become either directly or indirectly engaged on Government orders as to prevent or delay work on other orders, the Company shall be entitled at any time, on notice to the Buyer, to make partial deliveries only or to determine the contract without prejudice in any case to rights accrued in respect of deliveries already made.

9. Determination of Contract

The Company shall have the right forthwith to determine this and/or any other Contract between the Buyer and the Company by written notice to the Buyer's last known address (without prejudice to any claim or right the Company might otherwise make or exercise) in any of the following events:-

- If the Buyer shall make default in or commit a breach of any contract with the Company; or
- If any distress or execution shall be levied upon the Buyer's property or assets; or
- If the Buyer shall make or offer to make any arrangements or composition

with creditors, or commit any act of bankruptcy or become insolvent; or

- If any petition or receiving order in bankruptcy shall be presented or made against him; or
- If the buyer shall be a limited Company and become subject of any resolution or petition for winding up or administration; or
- If a receiver or manager of the Buyer's undertaking, property or assets or any part thereof shall be appointed.

10. Indemnity

The Buyer will indemnify the Company against all damages, penalties, costs and expenses to which the Company may become liable as a result of work done to the Buyer's instructions or which infringe any letters, patent or registered design or copyright or any other third party intellectual property rights.

11. Prices

The price payable for the goods shall unless otherwise agreed be the Company's list price current at the date of despatch. Such prices are inclusive of delivery to the Buyer's UK mainland delivery point but costs of delivery to any other destinations will be charged to the Buyer.

12. Risk and Title

- Risk shall pass to the Buyer so that the Buyer is responsible for all loss, damage or deterioration to the goods:
 - If the Company delivers the goods by its own transport at the time when the goods or a relevant part thereof arrive at the place of delivery; or
 - In all other circumstances at the time when the goods, or a relevant part thereof leave the premises of the Company whether or not the Company arranges transport and (without prejudice to clause 7) where the goods are delivered by carrier, any claims for loss or damage in transit must be made by the Buyer against the carrier in accordance with the carrier's conditions.
- Title to the goods supplied under the contract shall only pass to the Buyer when payment in full for all goods supplied under this and all other contracts between the Company and the Buyer has been received by the Company. The Company reserves the immediate right to possession of and at any time may recover all goods in respect of which title has not passed to the Buyer; the Company is hereby authorised by the Buyer to enter upon any premises where such goods are held by or on behalf of the Buyer and recover possession thereof.
- Until title to goods has been passed to the Buyer pursuant to these conditions it shall possess the goods as a Bailee at will of the Company, and the Buyer shall not be entitled to sell or otherwise deal in goods in respect of which title has not passed to the Buyer. If the Buyer acts in breach of these conditions then without prejudice to any other rights of the Company the Buyer shall have a fiduciary duty to account to the Company for the proceeds of any sale save to the extent that any such proceeds exceed the amounts owed to the Company under this and all other contracts between the Company and the Buyer.

13. Cancellation

Cancellation will only be accepted by the Company on condition that all costs and expenses incurred by the Company up to the time of cancellation and all loss of profits and other loss or damage suffered by the Company as a result of such cancellation will be paid forthwith by the Buyer to the Company.

14. Payment of Accounts

- Unless otherwise agreed by the Company in writing, payment shall be settled in full by the last working day of the month following the month in which the goods were despatched, or would have been despatched save for postponement otherwise than due to default on the part of the Company. The Company shall be entitled to submit its invoice on the same day as its delivery advice note or at any time thereafter, save that where delivery has been postponed at the request of or the default of the Buyer, then the Company may submit its invoice at any time after the goods are ready for delivery or would have been ready in the ordinary course but for the request or default as aforesaid.
- The Company reserves the right to charge interest at a rate up to 5% above Lloyds Bank Base Lending Rate ruling at the time payment is due if payment is not made in accordance with the terms agreed at the time the order is accepted.

15. VAT

Retail prices include VAT @ 20%

16. Consumer Protection Act

- In circumstances where the Company supplies parts or goods to the Buyer for incorporation with, or use ancillary to, any composite goods to be produced, manufactured, processed or supplied by the Buyer then:
- The Buyer shall forthwith on demand produce for inspection by the Company copies of all written instructions, information and warnings in relation to the said composite goods, provided nevertheless that such inspection or right to inspect shall not of itself constitute acceptance or approval on the part of the Company of such instructions, information, or warnings; and
 - The Buyer shall indemnify, reimburse and compensate the Company for all losses and damages (including costs, expenses and charges for legal actions in which the Company may be involved) that the Company may incur in the event that any claim or claims are made against the Company pursuant to the Act relating to the said composite goods of the Buyer or parts or goods supplied hereunder in circumstances in which the parts or goods supplied by the Company was either:
 - Not the defective part of the said composite goods; or
 - Was only rendered the defective part or became defective goods by reason of actions or omission of the Buyer; or
 - Was only rendered the defective part or became defective goods by reason of instructions or warnings given or omitted by the Buyer or other supplier of the said composite goods supplied hereunder.
 - For the purposes of this condition the word "defective" shall be interpreted in accordance with the definition contained in the Act and this condition shall mutatis mutandis apply in relation to equivalent legislation of other states as it applies in relation to the Act.

17. Law and Jurisdiction

This contract shall be governed and construed according to the Law of England and the parties hereby agree to submit to the exclusive jurisdiction of the English courts.

For further information,
please contact your appropriate
sales office or visit our website

www.pegleryorkshire.co.uk

UK ENQUIRIES

Switchboard:

Tel: 0844 243 44 00

Fax: 0844 243 98 70

HOME SALES

Tel: 0800 156 00 10

Fax: 0808 156 10 11

Email: uk.sales@pegleryorkshire.co.uk

BROCHURE HOTLINE

Tel: 0800 156 00 20

Fax: 0808 156 10 11

TECHNICAL HELPLINE

Tel: 0800 156 00 50

Fax: 0808 156 10 12

EXPORT

Tel: +44(0) 1302 855 656

Fax: +44(0) 1302 730 513

Email: export@pegler.yorkshire.co.uk

Registered in England
Company No. 00401507

REGISTERED OFFICE

Pegler Yorkshire Group Ltd
Haigh Park Road, Stourton
Leeds, West Yorkshire
LS10 1RT
England

Pegler Yorkshire Group Ltd
St Catherine's Avenue, Doncaster
South Yorkshire DN4 8DF

Tel: 0844 243 44 00

Fax: 0844 243 98 70

 Pegler Yorkshire

Maintaining a policy of continual product development Pegler Yorkshire Group Ltd reserves the right to change specifications, design and materials of products listed in this brochure without prior notice. Product colours in this brochure are as close as the printing process allows.

Lit ref: WEB ONLY